

Pos.Nr. Pos.no. Position	Beschreibung Description Désignation	Preisgruppe Price bracket Catégorie de prix	
		Art.-Nr. Art.no. Réf.	
1	Motor Motor	85093	57
2	Stromabnehmer Pantograph	85394	39
3	Schraube M 2x7 Screw M 2x7	85673	2
4	Schraube 2.2x9.5 Screw 2.2x9.5	85808	2
5	Kardanschale kurz Cardan bearing short	87129	3
6	Platine kpl. Printed circuit assembly	87838	38
7	Stützisolator Support insulator	88001	2
8	Lokpfeife Loco whistle	88002	6
9	Isolator Insulator	88010	2
10	Druckluftschalter Air compression switch	88024	3
11	Trenisolator Separate insulator	88107	2
12	Isolator Hauptleitung Insulator main lead	88137	4
13	Isolator für Pantograph Insulator (Pantograph)	88150	3
14	Topf kurz Can short	88151	2
15	Isolator mit Ltg. Insulator	88152	2
16	Trenschalter Separate Switch	88153	3
17	Puffer flach Buffer flat	88502	4
18	Puffer gewölbt Buffer vaulted	88503	4
19	Oberleitungsverbindung Overhead connection	89774	6
20	Dachleitung Roof wire	92677	6
21	Fenstersatz Window set	92679	16
22	Griffstange Handle bar	92688	3
23	Lüftersatz Fan set	97884	16
24	Trittbrett Running board	97885	3
25	Führerstand Drivers cab	97886	6
26	Lichtleitstäbesatz Light transmissions bar set	97887	9
27	Brückenstecker Connector	100644	7
28	Distanzplättchen Spacer	105764	2
29	Griffstange Nirosta Handle bar	106498	4
30	Isolator Insulator	108015	2
31	Drahtlampe 16V Light bulb	109321	10
32	Drahtlampe 16V rot Light bulb red	109918	10
33	Kontakthalter kpl. Contact fastener	110292	12
34	Senkantrieb Pantograph cylinder	113979	2
35	Lampen-Flexplatine Bulb printed	114377	26
36	Gehäuse kpl. Betr. Nr. E 50 032 Body assembly Betr. No. E 50 032	114378	68
~ Wechselstrom / AC			
37	Decoder Motorola last. Decoder Motorola	10738	---

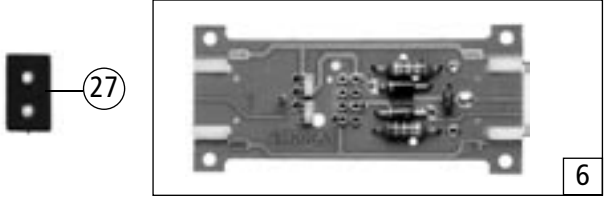

Pos.Nr. Pos.no. Position	Beschreibung Description Désignation	Preisgruppe Price bracket Catégorie de prix	
		Art.-Nr. Art.no. Réf.	
1	Hafringsatz DC Traction Tyre DC	85622	19
2	Schraube M 2X6 Screw M 2x6	85672	2
3	Schraube M 2X8 Screw M1,6	85674	2
4	FK-Schraube m. Gewindeauslauf FK-Screw	85704	3
5	Schraube M1,6X4 Screw M1,6x4	85815	2
6	Feder Spring	86202	2
7	Zahnrad Z=19 Gear Z=19	86417	2
8	Zahnrad Gear	86460	2
9	Zwischenzahnrad Between gear	86480	2
10	Schneckenzahnrad Worm gear	86490	4
11	Zahnrad Gear	86493	2
12	Kupplungshalter (o. Abb.) Coupling holder (no. ill.)	89274	3
13	Universalkupplung höhenverst. Universal coupling	89283	5
14	Lager für Schneckenachse Jurnal for worm axis	89749	6
15	Achse 2.6X7.5 Axle 2,6x7,5	89910	2
16	Achse 2.0X7.5 Axle 2,0x7,5	89911	2
17	Zahnrad Z=12 Gear Z=12	94953	2
18	Kardanwelle Cardan axle	100260	3
19	Attrappenrahmen klein Push in part set, smal	107808	3
20	Lok Unterteil Base frame	109777	26
21	Lampenhalter Lamp holder	109778	3
22	Magnetbremse Magnetic brake	109779	2
23	Schneckensatz Worm set	109781	24
24	Getriebeteilesatz Gear part set	109783	24
25	Blende kpl. Frame assembly	109784	28
26	Lampenhalteplättchen Lamp holder plate	109827	2
27	Kontakthalter kpl. current contact frame assembly	110292	12
28	Schneckendeckel mit Stab, Feder Worm cover w. vibration damper	110314	8
29	KK-Sonderaufnahme KK-Coupling holder	110325	3
30	Beilagscheibe 2,1x4x0,3 Shim 2,1x4,03	113969	2
31	Zurüstbeutel Bag with accessories	114379	25
32	Radsatz mit 2 Hafringen Wheelset with 2 traction tires	114380	20
33	Radsatz ohne Hafring Wheelset without traction	114381	18
34	Teilesatz Parts set	114382	7
~ Wechselstrom / AC			
35	AC-Flüsterschleifer kurz Wiper wiper, short	40064	---
36	Hafringsatz Traction Tyre	85623	16
37	Schraube M1,6X10 Screw M1,6x10	85746	2
38	Getriebeteilesatz Gear set	109798	24
39	Schraube M 1,6X5 Screw M 1,6x5	110008	2
40	Radsatz mit 2 Hafringen Wheelset with 2 traction tires	114383	20
41	Radsatz ohne Hafring Wheelset without traction	114384	18
42	Radsatz ohne Zahnrad Wheelset without gear	114385	16

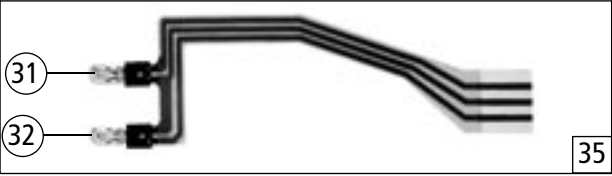
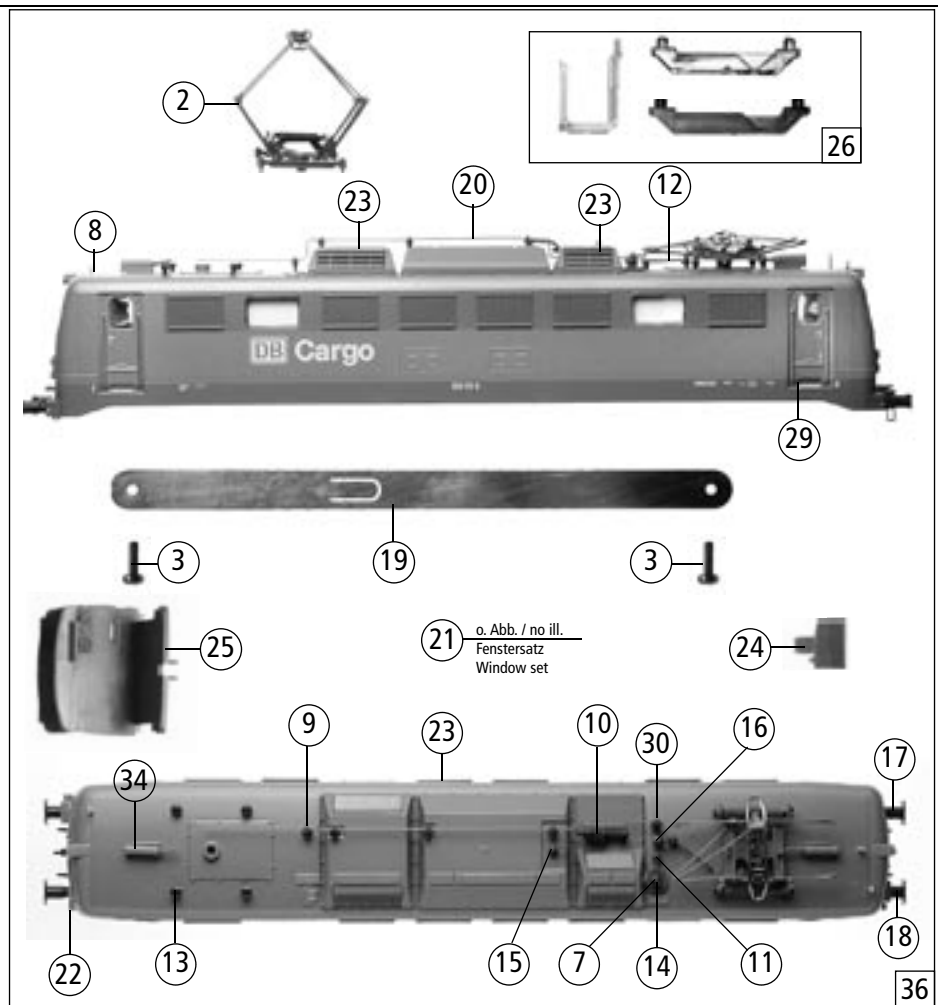
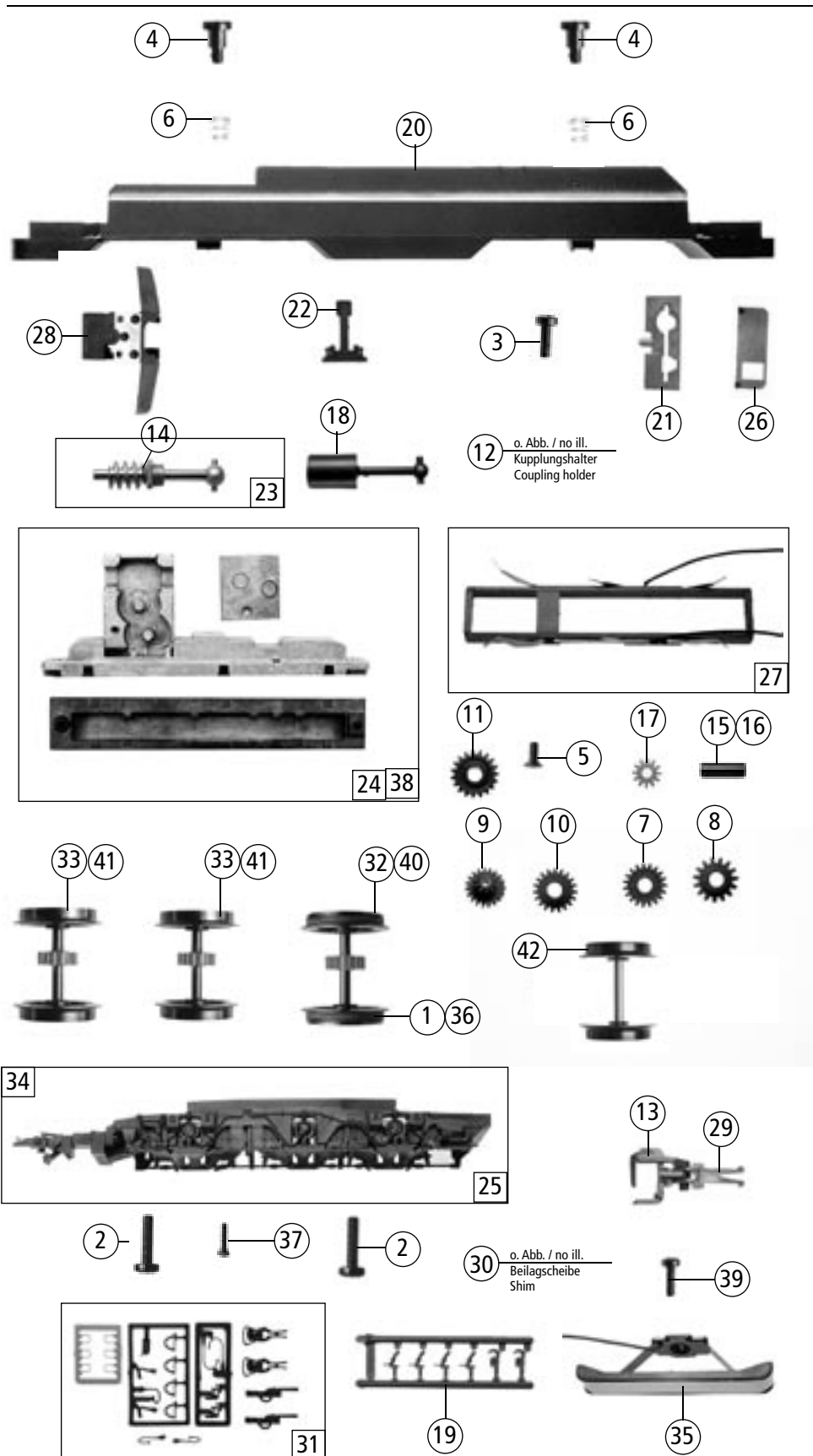

Ersatzteile erhalten Sie bei Ihrem Fachhändler, Ihrer Landesvertretung, oder bei:
You can order your Replacement Parts at your local dealer, your country representative, or:
Passez commande des pièces détachées chez votre détaillant, chez le S.A.V. de votre importateur national ou en direct au S.A.V. ROCO:

ROCO Modellspielwaren VertriebsgmbH & Co. Handels KG
— Service —
Georg-Wrede-Straße 49, D-83395 Freilassing
☎ +49 / (0)86 54 / 47 63 0
Fax: +49 / (0)86 54 / 47 63 50
E-Mail: service@roco-online.de